

Supercritical 24

Constant Flow/Constant Pressure Dual Piston Pump



Operator's Manual

90-2476 REV V



WARNING: This pump is rated for use with carbon dioxide only. This pump is not intended for use with flammable materials.

NOTE: If water is used to flush or clean the pump, it must be followed with a 100% Methanol flush or Nitrogen purge, otherwise damage to the pump may occur.

SAFETY SYMBOLS



EARTH GROUND



CAUTION - REFER TO MANUAL



CAUTION HIGH VOLTAGE



TABLE OF CONTENTS

1	INTRODUCTION	1-1
1.1	Description of the Pump	1-1
1.1.1	Wetted Materials	1-1
1.2	Specifications for the Supercritical 24 Constant Flow Pump	1-2
1.3	Specifications for the Supercritical 24 Constant Pressure Pump	1-3

2	INSTALLATION	2-1
2.1	Unpacking and Inspection	2-1
2.2	Location/Environment	2-1
2.3	Electrical Connections	2-1
2.4	Instrument Installation	2-1
2.4.1	CO2 Dip Tank	2-1
2.4.2	CO2 Tank Adapter	2-1
2.4.3	Outlet Tubing	2-2
2.4.4	Bleeding CO2 Through the Pump	2-2
2.4.5	Cooler Pre-Run	2-2
2.4.6	Priming the Pump	2-2
2.5	Preparation for Storage or Shipping	2-2

3	OPERATION	3-1
3.1	Turing the Unit ON	3-1
3.2	Front Panel Controls and Indicators	3-1
3.2.1	Filter/inlet and Filter/Outlet	3-1
3.2.2	Control Panel - Constant Flow pump	3-2
3.2.3	Control Panel – Constant Pressure Pump	3-4
3.3	Rear Panel Remote Input	3-9

4	MAINTENANCE	4-1
4.1	Filter Replacement	4-1
4.1.1	Inlet/Outlet Filters	4-1
4.2	Heatsink/Peltier/Pre-Cooler Assembly Removal	4-2
4.3	Changing the Pump Heads	4-3
4.3.1	Removing the Pump Head	4-3
4.3.2	Cleaning the Pump Head Assembly	4-4
4.3.3	Replacing Piston Seals	4-5
4.3.4	Changing the Piston	4-6
4.3.5	Replacing the No-Flush Housing and Pump Head	4-6
4.3.6	Replacing the Heatsink/Peltier/Pre-Cooler Assembly	4-7

4.4	Conditioning New Seals	4-7
4.5	Check Valve Cleaning and Replacement	4-7
4.6	Cleaning the Pump	4-8
4.7	Lubrication	4-8
4.8	Fuse Replacement	4-8
4.9	Battery Replacement (if applicable)	4-9
<hr/>		
5	QUICK GUIDE TO PROBLEM SOLVING	5-1
6	LIST OF REPLACEMENT PARTS	6-1
6.1	Supercritical Pump, Stainless Steel	6-1
6.2	Seals	6-1
6.3	General	6-1
<hr/>		
7	APPENDIX A	7-1
7.1	Rear Panel Remote Input	7-1
7.1.1	Hardware Implementation	7-1
7.1.2	Hand-Shaking	7-2
7.1.3	Command Interpreter	7-2
7.2	Rear Panel 6-Pin and 10-Pin Terminal Board Connectors	7-4
7.2.1	Pressure Fault and Motor Stall Fault Output	7-4
7.2.2	General Information on Inputs	7-4
7.2.3	General Information on Run, Stop, and Enable Inputs	7-5
7.2.4	Run and Stop Inputs	7-5
7.2.5	Enable Input	7-5
7.2.6	General Information on Voltage and Frequency Inputs	7-5
7.2.7	Voltage Input	7-6
7.2.8	Frequency Input	7-6
<hr/>		
8	WARRANTY STATEMENT	8-7

1 INTRODUCTION

This operator's manual contains information needed to install, operate, and perform user maintenance on the Supercritical 24 Constant Flow or Constant Pressure pump.

1.1 Description of the Pump

The Supercritical 24 **Constant Flow** pump is designed to be a reliable component wherever a constant flow must be maintained. The flowrate of the Supercritical 24 pump fitted with two standard 12 mL pump heads can be set in 0.01-mL/min increments from 0.00 to 24.0 mL/min.

The Supercritical 24 **Constant Pressure** pump is designed to be a reliable component wherever a constant pressure must be maintained. Pressure can be set in 10-psi increments from 0 to 10,000 psi.

1.1.1 *Wetted Materials*

Pump heads are made of Aluminum, check valve bodies and outlet tubing are made of stainless steel. Other materials common to the Supercritical 24 pump are synthetic ruby and sapphire (check valve internals and piston), Tefzel (check valve washers), and UHMW-PE (hi-pressure seals).

1.2 Specifications for the Supercritical 24 Constant Flow Pump

Flow Rates.....	0.01 to 24.00 mL/min
Pressure	0 to 10,000 psi
Pressure Accuracy	±2% of full scale pressure
Pressure Zero Offset	-0 psi +10psi
Flow Accuracy	±2% using 100% Methanol @ 1,000 psi ±5% using CO ₂ (Based on gas volume measurements and back calculation to liquid)
Flow Precision	0.5% RSD using 100% Methanol @ 1,000 psi
Dimensions.....	5.75" high x 11.125" wide x 21.125" deep (15 x 28 x 54 cm)
Weight	36.4 lb (16.5 Kg)
Power	100-120 VAC, 50-60 Hz; or 220-240 VAC, 50-60 Hz
Features	<ul style="list-style-type: none">• Autoprime™ one button toggles flowrate to maximum• Check valves allow reliable flowrates down to 0 psi• Inlet & outlet bulkhead filters• Aluminum pump heads in 12 mL/min size• Hex tee/Pressure transducer which adds no volume to the system• Front panel flow adjustment in 0.01 mL/min increments• Optional User-settable upper and lower pressure limits. The pump is automatically stops if the pressure drops below the preset lower pressure limit (the lower pressure limit is enabled after 50 pump strokes) or if the pressure exceeds the upper pressure limit.• Microprocessor advanced control• Chemical-resistant keypad• Chemical-resistant LED digital display—shows flowrate and pressure limits• Digital stepper motor design prevents flowrate drift over time and temperature which is a common problem found in analog designs
Back Panel Inputs.....	<ul style="list-style-type: none">• Run/Stop Inputs (5 volt TTL type)• 0 to 10 volt flowrate control input• 0 to 10 KHz flowrate control input• RS232 serial communications port for complete control and status monitoring
Back Panel Output.....	Normally open and normally closed relay contacts (SPDT, form C, 0.25 amp max., 50 volt max.) indicate when a pressure fault or motor stall fault occurs.
Pulsation.....	±1% @ 12 mL/min using 100% Methanol @ 1,000 psi

1.3 Specifications for the Supercritical 24 Constant Pressure Pump

Flow Rates.....	0.01 to 24.00 mL/min
Pressure	0 to 10,000 psi
Pressure Accuracy	±2% of full scale pressure
Pressure Zero Offset	-0 psi +10psi
Press. Control Accy	<10% or 100 psi, whichever is larger
Dimensions.....	5.75" high x 11.125" wide x 21.125" deep (15 x 28 x 54 cm)
Weight	36.4 lb (16.5 Kg)
Power	100-120 VAC, 50-60 Hz; or 220-240 VAC, 50-60 Hz
Features	<ul style="list-style-type: none">• Autoprime™ one button toggles flowrate to maximum• Check valves allow reliable flowrates down to 0 psi• Inlet & outlet bulkhead filters• Aluminum pump heads in 12 mL/min size• Hex tee/Pressure transducer which adds no volume to the system• Front panel pressure adjustments 10-psi increments• Optional User-settable upper and lower pressure limits. The pump is automatically stops if the pressure drops below the preset lower pressure limit (the lower pressure limit is enabled after 50 pump strokes) or if the pressure exceeds the upper pressure limit.• Microprocessor advanced control• Chemical-resistant keypad• Chemical-resistant LED digital display—shows flowrate and pressure limits• Digital stepper motor design prevents flowrate drift over time and temperature which is a common problem found in analog designs
Back Panel Inputs.....	<ul style="list-style-type: none">• Run/Stop Inputs (5 volt TTL type)• 0 to 10 volt flowrate control input• 0 to 10 KHz flowrate control input• RS232 serial communications port for complete control and status monitoring
Back Panel Output.....	Normally open and normally closed relay contacts (SPDT, form C, 0.25 amp max., 50 volt max.) indicate when a pressure fault or motor stall fault occurs.

2 Installation

2.1 Unpacking and Inspection

Prior to opening the shipping container, inspect it for damage or evidence of mishandling. If it has been damaged or mishandled, notify the carrier before opening the container. Once the container is opened, inspect the contents for damage. Any damage should be reported to the carrier immediately. Save the shipping container. Check the contents against the packing list.

2.2 Location/Environment

The preferred environment for the pump is normal laboratory conditions. The area should be clean and have a stable temperature and humidity. The specific temperature and humidity conditions are 10 to 30 °C and 20% to 90% relative humidity. The instrument should be located on a stable flat surface with surrounding space for ventilation and the necessary electrical and fluid connections.

2.3 Electrical Connections

The Supercritical 24 pump is capable of accepting a wide range of input power, including 100-240VAC, 50/60Hz. The power input module is equipped with two 8A, 250V, 5x20mm Slo-Blo fuses. Refer to Section 5.8 for instructions on replacing the power entry module fuses.

Position the Supercritical 24 Pump so that there is at least a four inch clearance on all sides of the pump to permit proper ventilation. Plug the pump into a properly grounded electrical outlet using the power cord supplied with the pump.

WARNING: Do not bypass the safety ground connection as a serious shock hazard could result.

2.4 Instrument Installation

Proper solvent preparation will prevent a great number of pumping problems. The most common problem is bubble formation, which may affect the flow rate consistency. Aside from leaky fittings, the problem of bubble formation arises from two sources: solvent out-gassing and cavitation. Filtration of HPLC solvents is also required.

2.4.1 CO₂ Dip Tank

Connect a Carbon Dioxide bone dry grade (99.99% purity) CO₂ tank equipped with a dip tube or siphon tube to the inlet of the Supercritical 24 pump, using the adapter shown in figure 2-4. Note: 1/8" OD PEEK or SS tubing will be required for connection. Length of tubing will be dependent upon specific installation.

NOTE: Minimum tank pressure of 750 psi is required for proper operation of the pump. An in-line filter is also recommended prior to the pump, which should be available through your CO₂ tank supplier.

2.4.2 CO₂ Tank Adapter

A CO₂ tank adapter is supplied with the Supercritical 24 pump. The adapter provides a conversion from the CO₂ tanks 1/4 npt(M) pipe threads to 1/8" OD tubing.

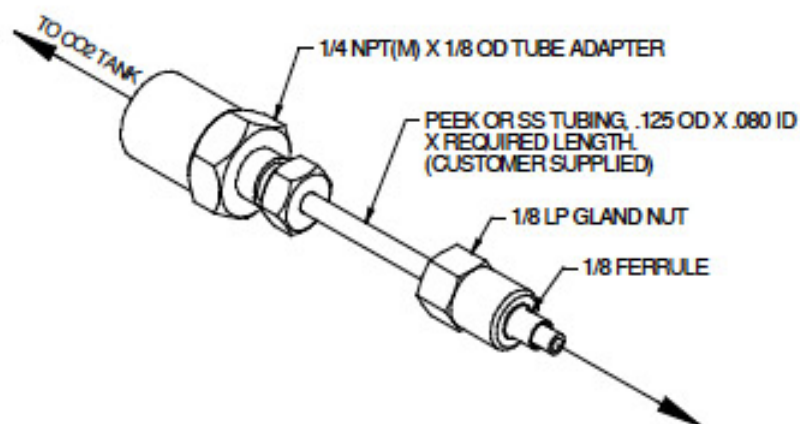

Figure 2-4 Tank Adapter

2.4.3 Outlet Tubing

Outlet tubing (not supplied with the pump) should have a 1/16" outer diameter. Type 316 stainless steel with a 0.040" inner diameter is normally used. The tubing must be cut squarely with no burrs. The tube itself should not be crimped and the center hole must be open. A tubing cutter is recommended for cutting stainless steel tubing.

2.4.4 Bleeding CO₂ Through the Pump

CO₂ should be bled through the system for 30 minutes minimum, prior to operating the pump to remove moisture that could freeze, inhibiting the check valve operation or damaging the pump.

2.4.5 Cooler Pre-Run

The cooler built into the pump head/heatsink combination requires a 20 minute minimum pre-run in order to lower the pump head temperature to an acceptable level for pumping supercritical fluid.

2.4.6 Priming the Pump

Priming the pump is not necessary. If pressure does not increase in 1 to 2 minutes of operation at 50% of maximum speed (displayed on front panel), outlet may need to be restricted further to allow supercritical fluid to remain flooded in the pump heads.

2.5 Preparation for Storage or Shipping

CAUTION: Re-package in the original carton, if possible. If the original carton is not available, wrap the pump in several layers of bubble wrap and cushion the bottom, top, and all four sides with 2" of packaging foam. Although heavy, an HPLC pump is a delicate instrument and must be carefully packaged to withstand the shocks and vibration of shipment.

3 Operation

3.1 Turing the Unit ON

The main power switch is located at the rear of the unit, above the power entry module. When this switch is in the ON position, power will be supplied to the rear fan, the front panel display, the motor controller, and the front fan. Note, however, that the large front fan is controlled by a thermal switch. This switch suspends fan operation until it senses a temperature of 40° Celsius on the Heatsink connected to the cooling assembly. When this temperature is reached, the front fan will become enabled. This fan will then continue to run until the Heatsink temperature drops below the setpoint of 40° Celsius.

The cooling unit is controlled by the switch located beneath the front panel display. When this switch is in the ON position, power will be supplied to the cooling unit and the blue COOLING indicator located on the front panel. As noted above, when the cooling unit is powered on, heat will begin to accumulate on the Heatsink, and the front fan will become enabled. Power to the front fan is NOT controlled by the front switch. When the front switch is set to OFF, the front fan will continue to operate until the Heatsink temperature drops below 40° Celsius.

3.2 Front Panel Controls and Indicators

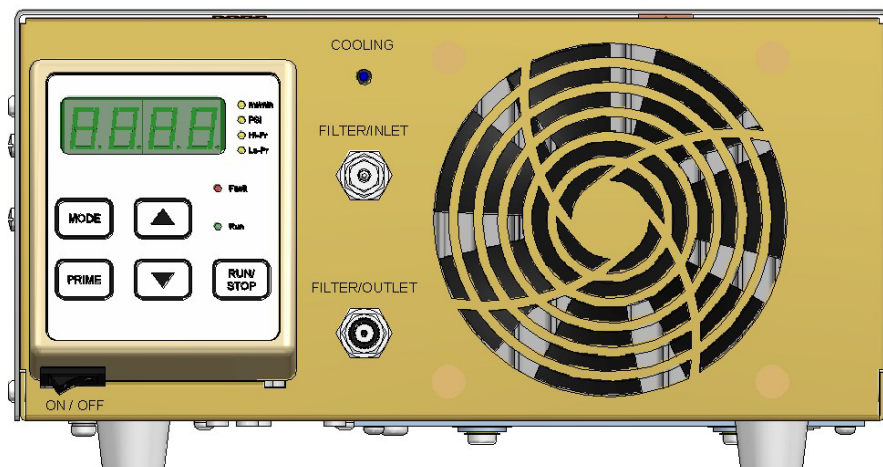

Figure 3-1. Supercritical 24 Pump Front Panel

3.2.1 Filter/inlet and Filter/Outlet

High-pressure bulkhead filters (10 micron rating) are included at the input and output of the Supercritical 24 pump. The Filter/Inlet and Filter/Outlet ports are high-pressure filter closures and are designed for a 1/8" OD tubing connection on the inlet and a 1/16" OD tubing connection on the outlet.

3.2.2 Control Panel - Constant Flow pump

(For constant pressure pump skip to section 3.2.3.)

3.2.2.1 Digital Display

The 4-digit display shows the pump flowrate (mL/min), system pressure (psi), or the set upper or lower pressure limit (psi) when operating. Choice of display is selected with the MODE button.

3.2.2.2 Keypad



This button alternately starts and stops the pump.



This button increases the flow rate.



This button decreases the flow rate.



When the PRIME button is pressed, the pump runs at the maximum flow rate for the pump head. It will stop when any button is pressed.



Use this button to cycle through the four display modes: flowrate, pressure, upper pressure limit, or lower pressure limit. A status LED to the right of the digital display indicates which mode is active.

Fast And Slow Button Repeat On The Up And Down Arrow Buttons:

If the UP-ARROW or DOWN-ARROW button is held down for more than approximately one half of a second, the button press will repeat at a slow rate of approximately 10 times a second. Once slow button repeat has begun, fast button repeat can be initiated by using a second finger to press down the second arrow button. During fast button repeat, the button press will repeat at a rate of approximately 100 times a second. Switching back and forth between repeat speeds can be accomplished by pressing and releasing the second arrow button while keeping the first arrow button held down.

3.2.2.3 Status LEDs

ML/MIN When lit, the digital display shows the flowrat in mL/min.

PSI When lit, the digital display shows the system pressure in psi

HI PRESS When lit, the display shows the user-set upper pressure limit in psi

LO PRESS When lit, the display shows the user-set lower pressure limit in psi.

PUMP RUN Lights to indicate that the pump is running

FAULT Lights when a fault occurs and stops the pump

3.2.2.4 Power-Up Configuration

Pressure Compensation: On power-up, press the PRIME button on the front panel while pressing the Power On switch on the rear of the pump. The pump will display a number from 0 to 100, this represents the running pressure of the pump which is 0 psi to 10000 psi. Each digit represents 100 psi. To change the pressure compensation number use the up arrow and down arrow buttons. When you have selected the correct pressure compensation press the RUN button to return to normal operation of the pump.

Non-volatile Memory Reset: If the pump is operating erratically, there is the possibility that the memory has been corrupted. To reset the memory and restore the pump to it's default parameters, press and hold the UP-ARROW button when the power is switched on. Release the button when the display reads "rES". The parameters stored in non-volatile memory, i.e., the flowrate, the pressure compensation, the voltage/frequency select, the lower pressure limit, and the upper pressure limit will be set to the factory default values. The head type setting is the only parameter not changed by the non-volatile memory reset function. If the firmware is upgraded to a newer version, a non-volatile memory reset will automatically occur the first time the power is switched on.

3.2.2.5 Power-UP Tests

Display Software Version Mode: The software version can be displayed during power-up by pressing and holding the RUN/STOP and the UP-ARROW buttons when the power is switched on. Release the buttons when the display reads "UER". The decimal point number displayed on the display is the software version. To exit this mode, press the RUN/STOP button.

Display Software Checksum Mode: If the pump is operating erratically, there is the possibility that the firmware stored in the program memory integrated circuit (EPROM) has been corrupted. Each version of firmware has a checksum which is printed on the EPROM's label. The pump's cover must be removed to gain access to the EPROM which is located on the Pump Control Board; therefore, this should be only done by a qualified technician. To verify that the firmware has not been corrupted, do the following: The software checksum can be displayed during power-up by pressing and holding the RUN/STOP and the DOWN-ARROW buttons when the power is switched on. Release the buttons when the display reads "CHE". After approximately 25 seconds, the 4-digit hexadecimal checksum will be displayed. To exit this mode, press the RUN/STOP button. If the checksum displayed does not match the checksum printed on the EPROM's label, the EPROM must be replaced.

NOTE: If the pump is operating correctly, the firmware version and checksum can be displayed then written in the manual for future comparison. This will save time during future troubleshooting since the pump's cover will not have to be removed to read the EPROM's label.

Align Refill Switch Mode: The signal that initiates the refill phase can be displayed during power-up by pressing and holding the PRIME and the UP-ARROW buttons when the power is switched on. Release the buttons when

the display displays "rFL". When the slotted disk allows the light beam to pass from the emitter to the detector on the slotted optical switch a pulse will be generated which signals the beginning of refill. When this pulse occurs the three horizontal segments displayed at the top of the display will turn off and the three horizontal segments at the bottom of the display will turn on. To exit this mode, press the RUN/STOP button.

Serial Port Loopback Test Mode: If an external device will not communicate to the pump via the serial port, the serial port loopback test can be used to verify that the serial port is functioning properly. During power-up press and hold the UP-ARROW and the DOWN-ARROW buttons when the power is switched on and then release the buttons. The display must display "C00" for the first half of the test to pass. Plug in the serial port loop back plug (A modular plug with pins 2 & 5 jumpered together and pins 3 & 4 jumpered together.). The display must read "C11" for the second half of the test to pass. To exit this mode, press the RUN/STOP button.

3.2.3 Control Panel – Constant Pressure Pump

(For constant flow pump see section 3.1.2.)

SPECIAL NOTE CONCERNING FLOW RATE LIMIT:

This pump is designed to operate in Constant Pressure Mode (flow rate auto-adjusts to maintained desired pressure). The user may also lower the maximum flow rate of the pump (12 or 24 mL/min maximum depending on model), particularly if pressure is overshooting while packing small bore columns.

When in Flow MODE (mL/min LED continuously lit), the user may lower the maximum flow rate using the UP & DOWN arrows as described below. This may be performed before the beginning of a run or during a run. Note that when in Maximum Flow MODE (ml/min indicator is on constant), the digital display shows only the upper flow rate limit, not the actual flow rate. The actual flow rate is displayed, using the MODE key, when the ml/min indicator is blinking.

3.2.3.1 Digital Display

The 4-digit display shows the pump's maximum flow rate (mL/min), pressure setting (PSI), the set upper or lower pressure limit (PSI), the actual pressure (PSI), or actual flow rate (mL/min) when operating. Choice of display is selected with the MODE button. **Pressure is set from the Pressure Mode Only (steady PSI light).**

3.2.3.2 Keypad



This button alternately starts and stops the pump.



This button increases the Pressure in Pressure MODEs or the Maximum Flow Rate in Flow MODE.



This button decreases the Pressure in Pressure MODEs or the Maximum Flow Rate in Flow MODE.



When the PRIME button is pressed, the pump runs at the maximum flow rate. It will stop when any button is pressed.



Use this button to cycle through five display modes: maximum flow rate, pressure setting, upper pressure limit, lower pressure limit or actual pressure. A status LED to the right of the digital display indicates which mode is active.

A steady PSI light indicates set pressure, a flashing PSI light indicates actual pressure. A steady mL/min light indicates maximum set flow rate, a flashing mL/min light indicates actual flow rate.

Fast And Slow Button Repeat On The Up And Down Arrow Buttons:

If the UP-ARROW or DOWN-ARROW button is held down for more than approximately one half of a second, the button press will repeat at a slow rate of approximately 10 times a second. Once slow button repeat has begun, fast button repeat can be initiated by using a second finger to press down the second arrow button. During fast button repeat, the button press will repeat at a rate of approximately 100 times a second. Switching back and forth between repeat speeds can be accomplished by pressing and releasing the second arrow button while keeping the first arrow button held down.

3.2.3.3 Status LEDs

- ML/MIN (steady)** When lit, the digital display shows maximum flow rate in mL/min.
- PSI (steady)**..... When lit, and not flashing, the digital display shows the pressure setting in PSI. UP and DOWN arrow keys set PRESSURE.
- HI PRESS** When lit, the display shows the user-set upper pressure limit in psi.
- LO PRESS** When lit, the display shows the user-set lower pressure limit in psi.
- PSI (flashing)** When flashing, the digital display shows the **actual** pressure in PSI
- ML/MIN (flashing)** When flashing, the digital display shows the **actual** flow rate in mL/min.
- PUMP RUN** Lights to indicate that the pump is running.
- FAULT** Lights when a fault occurs and stops the pump.

3.2.3.4 Power-Up Configuration

Pressure Compensation: On power-up, press the PRIME button on the front panel while pressing the Power On switch located on the rear of the unit. The pump will display a number from 0 to. This represents the running pressure of the pump which is 0 PSI to 10000. Each digit represents 100 PSI. To change the pressure compensation number use the up arrow and down arrow buttons. When you have selected the correct pressure compensation press the RUN button to return to normal operation of the pump.

Ramp Speed Adjustment & Packing Method: On power-up, press the PRIME button and the DOWN-ARROW button on the front panel while pressing the Power On switch located on the rear of the rear of the unit. The pump will first display a 0 or a 1 (packing method – see below) then a number from 10 to 500.

The 10 to 500 number is the percentage of the factory setting for the rate of change algorithm used to adjust the pumps speed as it ramps up and down to maintain the pressure setting. To change this percentage, use the up arrow and down arrow buttons. When you have selected the desired value for Ramp Speed Adjustment, press the RUN button to return to the normal operation of the pump.

Packing Method: The 0 or 1 is for Fast Packing ON or OFF. This controls the speed at which the pressure will build in the system.

On power-up, press the PRIME button and the DOWN-ARROW button on the front panel while pressing the Power On switch located on the rear of the unit. The pump will first display a 0 or a 1 then a number from 10 to 500. Press the PRIME button to set for Fast Packing On. This is best used in a larger sized silica column. Pressure will be allowed to rise to the user set maximum flow rate as rapidly as possible before being slowed and stabilized at the set pressure. Press the MODE button to set for Fast Packing Off. This is used when column size or material will cause a very rapid pressure rise before settling to a low flow rate. If the pressure rise becomes too rapid, the pump will slow down until the pressure rise slows, and the pump will slow as it narrows in on the set pressure.

Press the RUN button to return to the normal operation of the pump.

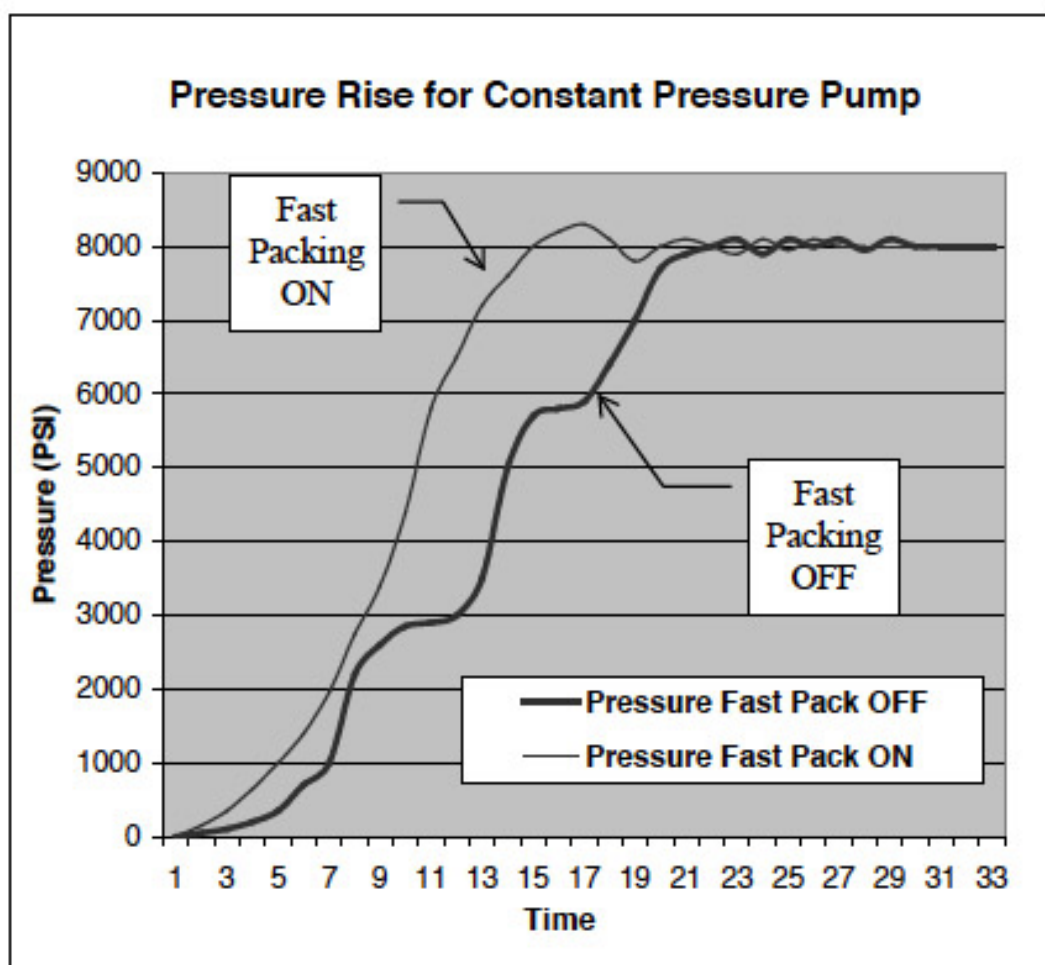

NOTE: Lowering the maximum flowrate in flow MODE (mL/min indicator lit) will also have a significant effect on how rapidly the pressure rises.

Non-volatile Memory Reset: If the pump is operating erratically, there is the possibility that the memory has been corrupted. To reset the memory and restore the pump to its default parameters, press and hold the UP-ARROW button when the power is switched on. Release the button when the display reads "rES". The parameters stored in non-volatile memory, i.e., the flow rate, the pressure compensation, the voltage/frequency select, the lower pressure limit, and the upper pressure limit will be set to the factory default values. The head type setting is the only parameter not changed by the non-volatile memory reset function. If the firmware is upgraded to a newer version, a non-volatile memory reset will automatically occur the first time the power is switched on.

3.2.3.5 *Power-Up Tests*

Display Software Version Mode: The software version can be displayed during power-up by pressing and holding the RUN/STOP and the UP-ARROW buttons when the power is switched on. Release the buttons when the display reads "UEr". The decimal point number displayed on the display is the software version. To exit this mode, press the RUN/STOP button.

Display Software Checksum Mode: If the pump is operating erratically, there is the possibility that the firmware stored in the program memory integrated circuit (EPROM) has been corrupted. Each version of firmware has a checksum which is printed on the EPROM's label. The pump's cover must be removed to gain access to the EPROM which is located on the Pump Control Board; therefore, this should be only done by a qualified technician. To verify that the firmware has not been corrupted, do the following: The software checksum can be displayed during power-up by pressing and holding the RUN/STOP and the DOWN-ARROW buttons when the power is switched on. Release the buttons when the display reads "CHE". After approximately 25 seconds, the 4-digit hexadecimal checksum will be displayed. To exit this mode, press the RUN/STOP button. If the checksum displayed does not match the checksum printed on the EPROM's label, the EPROM must be replaced. Note: If the pump is operating correctly, the firmware version and checksum can be displayed then written in the manual for future comparison. This will save time during future troubleshooting since the pump's cover will not have to be removed to read the EPROM's label.

Align Refill Switch Mode: The signal that initiates the refill phase can be displayed during power-up by pressing and holding the PRIME and the UP-ARROW buttons when the power is switched on. Release the buttons when the display displays "rFL". When the slotted disk allows the light beam to pass from the emitter to the detector on the slotted optical switch a pulse will be generated which signals the beginning of refill. When this pulse occurs the three horizontal segments displayed at the top of the display will turn off and the three horizontal segments at the bottom of the display will turn on. To exit this mode, press the RUN/STOP button.

Serial Port Loop back Test Mode: If an external device will not communicate to the pump via the serial port, the serial port loop back test can be used to verify that the serial port is functioning properly. During power-up press and hold the UP-ARROW and the DOWN-ARROW buttons when the power is switched on and then release the buttons. The display must display "C00" for the first half of the test to pass. Plug in the serial port loop back plug (A modular plug with pins 2 & 5 jumpered together and pins 3 & 4 jumpered together.). The display must read "C11" for the second half of the test to pass. To exit this mode, press the RUN/STOP button.

3.3 Rear Panel Remote Input

An RS-232C modular jack is provided on the back panel. A computer, with appropriate software, can be used as a remote control device for pump operation via this connection.

There are also two terminal board connectors provided for the run, stop, flowrate control frequency, and flowrate control voltage inputs.

See Appendix A for details on connection and operation.

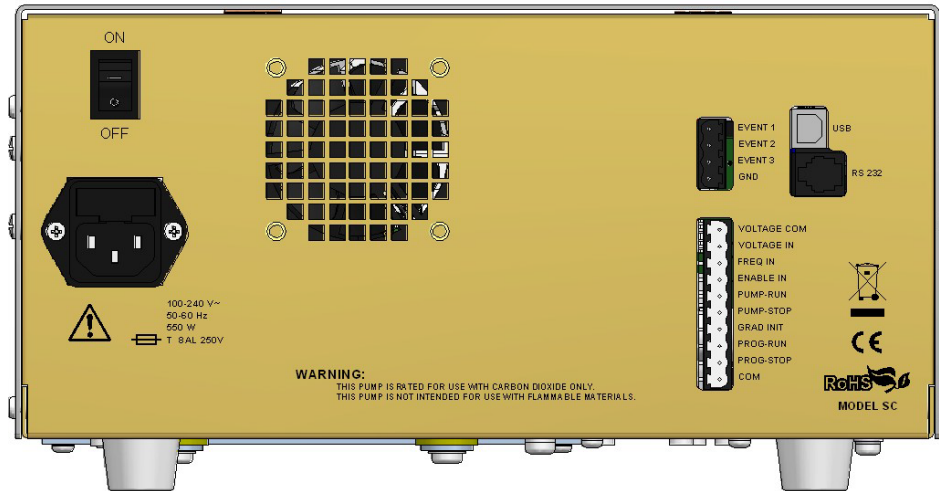

Figure 3-2. Supercritical Pump Rear Panel

4 Maintenance

Cleaning and minor repairs of the pump can be performed as outlined below.

Recommended maintenance schedule		
Item	Description	Period
Inlet/Outlet filter	Replace	Every 3 months
Seals	Replace	Every 6 months
Check Valves	Replace	Every 6 months
Pistons	Clean or replace	Every 12 months
Pump Heads	Clean or replace	Every 12 months

Note: Lower than normal pressure, pressure variations, or leaks in the pumping system can all indicate possible problems with the piston seal, piston, or check valves. Piston seal replacement could be necessary after 1,000 hours of running time. See Section 4.3.3.

4.1 Filter Replacement

4.1.1 Inlet/Outlet Filters

To service the inlet or outlet filters:

1. Unscrew the filter closure from the filter housing.

CAUTION: Do not use a metal object such as a screwdriver or paperclip to remove the seal. Doing so can scratch the precision surface of the seat and may cause the filter to leak.

2. Use a seal insertion/removal tool or a non-metallic object (such as a wooden toothpick) to remove the large seal that remains in the housing.
3. Unscrew the old filter and remove the small seal from the filter closure.
4. Place one of the small seals included in the replacement element kit over one of the new filters from the kit. Screw the new filter into the filter closure (finger tight).
5. Place one of the large seals from the replacement kit on the filter closure. Insert the filter closure into the housing and tighten. Torque to 160 in/lbs.

4.2 Heatsink/Peltier/Pre-Cooler Assembly Removal

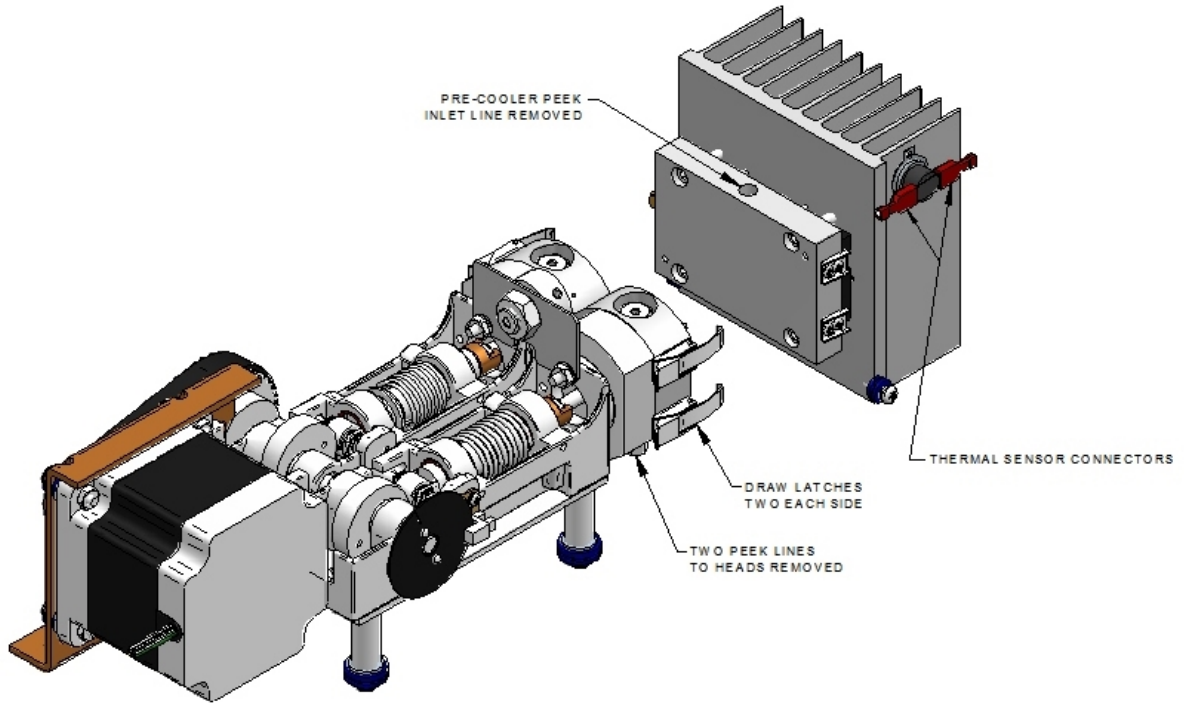

Figure 4-1 Heatsink/Peltier/Pre-Cooler Removal

To remove the Heatsink/Peltier/Pre-Cooler Assembly:

NOTE: Prior to heatsink/peltier/pre-cooler removal, the thermal insulation wrapped around the assembly must be removed carefully to preserve for reuse when reassembling.

1. Turn off power to the pump.
2. Remove Stainless Steel inlet line from top of pre-cooler.
3. Remove two Stainless Steel tubing lines from bottom of pre-cooler to bottom of pump heads.
4. Remove electrical connector from each side of heatsink/peltier/pre-cooler assembly.
5. Remove two screws and two grommets from cabinet supporting heatsink assembly.
6. Release four draw latches located on sides of pump heads and pre-cooler. Refer to figure 5-1.
7. Carefully pull heatsink/peltier/pre-cooler assembly away from pump heads until disengaged from alignment pins on pump heads. (Pull assembly straight forward toward front of cabinet).
8. After heatsink/peltier/pre-cooler assembly is disengaged from alignment pins, pull assembly up, out of cabinet.

4.3 Changing the Pump Heads

4.3.1 Removing the Pump Head

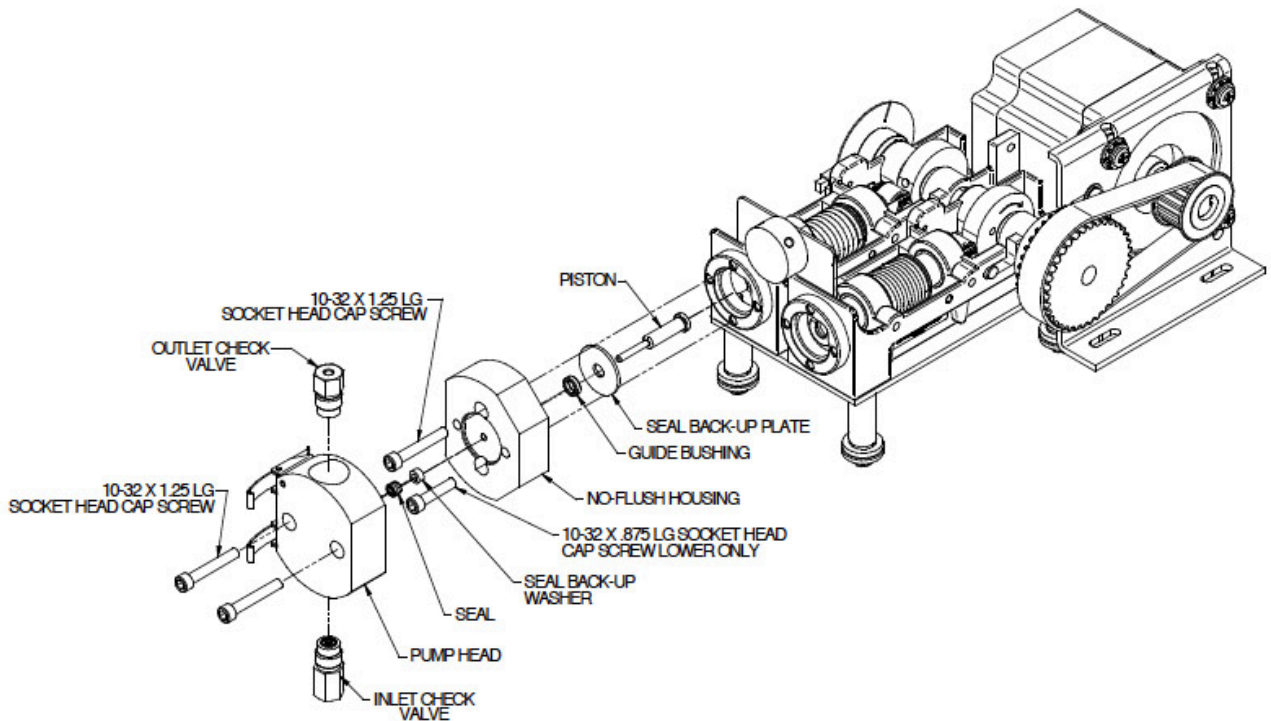

*Figure 4-2 Pump Head/No-Flush Housing Assembly
(Note: Only one head/no-flush housing shown for clarity.)*

1. Turn OFF the power to the Supercritical 24.
2. Unplug the power cord.
3. Remove the heatsink/peltier/pre-cooler assembly as described in section 4.2)
4. Remove the inlet lines from the inlet check valves.
5. Remove the outlet lines from the outlet check valves.
6. Carefully remove the two socket head cap screws at the front of the pump head.

CAUTION: Be careful not to break the piston when removing the pump head. Twisting the pump can cause the piston to break.

7. Carefully separate the pump head from the no-flush housing. Move the pump head straight out from the pump and remove it from the piston. Be careful not to break or damage the piston. Also remove the seal and seal back-up washer from the piston if they did not stay in the pump head.
8. Remove the thermal grease from the face of the pump head with a dry clean cloth to avoid spreading grease onto seals or piston.

9. Carefully remove the two socket head screws at the front of the no-flush housing. (Note: the longer screw is used in the upper position, and is used to fasten the connecting tee mounting plate.)
10. Carefully separate the no-flush housing from the pump. Move the no-flush housing straight out from the pump and remove it from the piston. Be careful not to break or damage the piston.

4.3.2 *Cleaning the Pump Head Assembly*

Note: If you choose to remove the piston seals, you should have a new set on hand to install after cleaning. It is not recommended that you install used piston seals since they are likely to be scratched and damaged during removal and would not provide a reliable seal if reused. If you decide to remove the seals, use only the flanged end of the plastic seal removal tool supplied with the seal replacement kit and avoid scratching the sealing surface in the pump head. See Section 4.3.3 for seal replacement instructions.

1. Inspect the piston seal cavity in the pump head. Remove any foreign material using a cotton swab, or equivalent, and avoid scratching the sealing surfaces. Repeat for the no-flush housing. Be sure no fibers from the cleaning swab remain in the components.
2. The pump head, check valves, and no-flush housing may be further cleaned using a laboratory grade detergent solution in an ultrasonic bath for at least 30 minutes, followed by rinsing for at least 10 minutes in distilled water, followed by a 100% Methanol final rinse. Be sure that any moisture and all particles loosened by the above procedures have been removed from the components before re-assembly.

WARNING: If removing the check valves, keep them in the orientation shown below the entire time they are not installed in the pump head. The assemblies may fall apart, parts may be lost, and they may not operate properly when re-assembled.

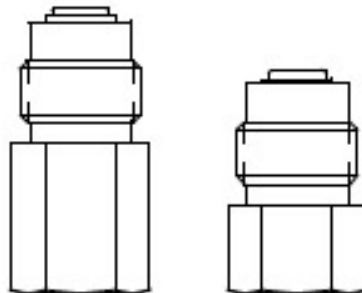

3. If the check valves have been removed, tighten the check valves on 75 inch-pounds.

Note: The inlet check valve has a larger opening (3/8"-24, flat-bottom seat) for the 1/8" inlet tubing; the outlet check valve has a smaller opening (#10-32, cone seat) for the 1/16" outlet tubing. The inlet check valve must be connected at the larger opening in the pump head. See Figure 4-3.

If the piston seals have been removed, insert new seals as described in Section 4.3.3, then continue with Section 4.3.5 to replace the pump head.

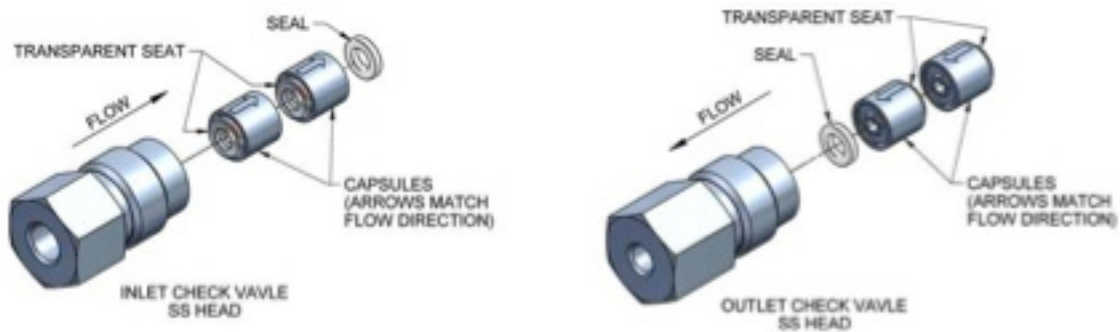

Figure 5-3 Check Valves

4.3.3 Replacing Piston Seals

Lower than normal pressure, pressure variations, and leaks in the pumping system can all indicate possible problems with the piston seal. Piston seal replacement is often necessary after 1000 hours of running time.

Each replacement seal kit contains one seal, one backup washer, one no-flush guide bushing, one seal insertion/removal tool, and a pad to clean the piston when changing the seal.

4.3.3.1 Removing the Seals

1. Remove the pump head as described in Section 4.3.1.
2. Insert the flanged end of the seal insertion/removal tool into the seal cavity on the pump head. Tilt it slightly so that flange is under the seal and pull out the seal.

CAUTION: Using any other “tool” will scratch the finish.

3. Inspect, and if necessary, clean the pump head as described in Section 4.3.2.

4.3.3.2 Cleaning the Piston

1. Once the pump head and no-flush housing are removed, gently remove the seal back-up plate by using either a toothpick or small screwdriver in the slot on top of the pump housing.
2. Grasp the metal base of the piston assembly so that you avoid exerting any side load on the sapphire rod, and remove the piston from the slot in the carrier by sliding it up.
3. Use the scouring pad included in the seal replacement kit to clean the piston. Gently squeeze the piston within a folded section of the pad and rub the pad along the length of the piston. Rotate the piston frequently to assure the entire surface is scrubbed. Do not exert pressure perpendicular to the length of the piston, as this may cause the piston to break. After scouring, use a lint-free cloth, dampened with alcohol, to wipe the piston clean.

4. Grasp the metal base of the piston assembly, and insert it into the slot in the piston carrier until it bottoms in the slot.

4.3.3.3 Replacing the Seals

1. Place a high pressure replacement seal on the rod-shaped end of the seal insertion/removal tool so that the spring is visible when the seal is fully seated on the tool. Insert the tool into the pump head so that the open side of the seal enters first, facing the high pressure cavity of the pump head. Be careful to line up the seal with the cavity while inserting. Then withdraw the tool, leaving the seal in the pump head. When you look into the pump head cavity, only the polymer portion of the seal should be visible.
2. Place seal back-up washer over the high pressure seal. Place seal back-up plate back into pump housing if it was removed. Orientation is not important in these cases.
3. Place a no-flush guide bushing on the piston.
4. Attach the no-flush housing as described in section 4.3.5.
5. Attach the pump head as described in Section 4.3.5.
6. Condition the new seal as described in Section 4.4.

4.3.4 Changing the Piston

1. Remove the pump head as described in Section 4.3.1.
2. Grasp the metal base of the piston assembly so that you avoid exerting any side load on the sapphire rod, and remove the piston from the slot in the carrier by sliding it up.
3. Grasp the metal base of the replacement piston assembly, and insert it into the slot in the piston carrier until it bottoms in the slot.
4. Attach the pump head as described in Section 4.3.5.

4.3.5 Replacing the No-Flush Housing and Pump Head

1. Make sure that the longer flat of the no-flush housing is to the outside of the assembly. Carefully align the no-flush housing and gently slide it into place on the pump. If misalignment with the piston occurs, gently push up on the piston holder.
2. Install the two socket head cap screws through the no-flush assembly. Tighten screws alternately. Note: The 1.25" long screw is used in the upper position to mount the connecting tee mounting bracket, and requires a flat washer/lock washer, and hex nut, on back side of mounting plate.
3. Line up the pump head and carefully slide it into place. Be sure that the inlet valve is on the bottom and the outlet valve is on the top. Do not force the pump head into place.
4. Install socket head cap screws through the pump head. To tighten firmly, alternately turn screws 1/4 turn while gently wiggling the pump head to center it. Pump heads must be flush across their faces. Check by holding a straight edge across both pump heads. Adjust by tightening screws where required.

5. Re-attach the inlet and outlet lines.

4.3.6 Replacing the Heatsink/Peltier/Pre-Cooler Assembly

1. Apply a thin, even coating of thermal grease to face of pre-cooler where it mates with the pump heads. Reference figure 4-1 for orientation of assembly.
2. Slide Heatsink/Peltier/Pre-cooler assembly down between heatsink fan and pump heads.
3. Align two holes on the pre-cooler with the two pins on the opposite corners of the pump heads.
4. Slide Heatsink/Peltier/Pre-cooler assembly back onto pins.
5. Attach draw latches to Heatsink/Peltier/Pre-cooler assembly, and lock in place.
6. Install electrical connectors on each side of Heatsink/ Peltier/Pre-cooler assembly.
7. Connect two Stainless Steel tubing lines from pre-cooler to pump heads.
8. Connect Stainless Steel inlet line at top of pre-cooler.
9. Wrap thermal insulation around assembly, and tape in place.

4.4 Conditioning New Seals

Note: Use only 100% Methanol to break-in new seals

Using a restrictor coil or a suitable column, run the pump with 100% methanol for 60 minutes at a back pressure of 500psi, and a flowrate of 1- 3mL/minute.

4.5 Check Valve Cleaning and Replacement

Many check valve problems are the result of small particles interfering with the operation of the check valve. As a result, most problems can be solved by pumping a strong solution of liquid, laboratory grade detergent through the check valves at a rate of 10 mL/min for one hour. After washing with detergent, pump distilled water through the pump for fifteen minutes. After pumping distilled water, pump 100% Methanol for fifteen minutes. Always direct the output directly to a waste beaker during cleaning. If this does not work, the check valve should be replaced.

WARNING: When removing the check valves, keep them in the orientation shown below the entire time they are not installed in the pump head. The assemblies may fall apart, parts may be lost, and they may not operate properly when re-assembled.

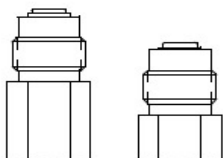

4.6 Cleaning the Pump

1. Disconnect the column inlet tube from the column.
2. Direct the column inlet tube (the tube from the injector outlet) to a waste beaker.
3. Set the flowrate to maximum.
4. Turn the injector to the INJECT position.
5. Pump 100% Methanol through the pump and injector for 3 minutes.
6. Pump 100% filtered, distilled water through the pump and injector for 3 minutes.

WARNING: Use standard laboratory procedures and extreme care when handling strong acids and bases.

7. Pump a 20% nitric acid/water solution through the pump and injector for 3 minutes.
8. Flush the pump and injector with 100% filtered, distilled water for at least 3 minutes.
9. Pump 100% methanol through the pump and injector for 3 minutes.

The pump is now prepared for short- or long-term shutdown.

4.7 Lubrication

The Supercritical 24 pump has modest lubrication requirements. The bearings in the pump housing and piston carrier are permanently lubricated and require no maintenance. A small dab of a light grease such as Lubriplate 630-AA on the cams is the only recommended lubrication. Be sure not to get lubricant on the body of the piston carrier, as this can retard its movement and interfere with proper pumping.

Note: Keeping the interior of the pump free of dirt and dust will extend the pump's useful life.

4.8 Fuse Replacement

Three fuses protect the Supercritical 24 pump. Two of the fuses are located in the power entry module at the rear of the cabinet and are in series with the AC input line. The other fuse is located on the motor power circuit board and is in series with the 58 Vdc supply.

Troubleshooting the fuses is straightforward. If the power cord is plugged in and the ON/OFF power entry switch is ON and the fan does not run, check the two fuses in the power entry module. To gain access to these fuses, gently pry off the cover plate with a small flat-bladed screwdriver. Replace with fuses of the correct rating: 6.25A slow-blo for 115 Vac pumps, or (2) 3.15A slow-blo for 230 Vac pumps.

If the front panel appears to function normally but the pump motor does not run, check the fuse located on the motor power circuit board. Replace it with a 10 A fast-blo fuse.

4.9 Battery Replacement (if applicable)

See photo below for battery option.

Depending on the version of drive board assembly installed, the board may not have a battery. If the printed circuit board does not have a battery, it is designed with circuitry that does not require a battery backup and you should disregard the following instructions.

The battery provides power for the memory that holds the current pump configuration. If the pump is set at a flowrate and the power is turned off, when the power is turned back on the flowrate should appear as it was set. If this flowrate does not appear the battery will need replaced.

CAUTION: Be sure to disconnect power cord before removing cover to insure there is no voltage present.

CAUTION: Circuit boards can be damaged by Electro Static Discharge (ESD). Follow standard ESD procedures when handling circuit boards.

1. Unplug the unit.
2. Remove the cover.
3. Turn the unit so that the pump heads are to the right. The battery can be seen in the lower right corner of the circuit board. The battery is circular and has a positive pole mark (+) on the top. Gently pull it from its socket.
4. With the positive mark (+) up, gently slide the new battery into the battery socket. Be sure the battery is all the way into place. It must contact the base of the battery socket.
5. Replace the cover to the unit.
6. Plug the unit back in.

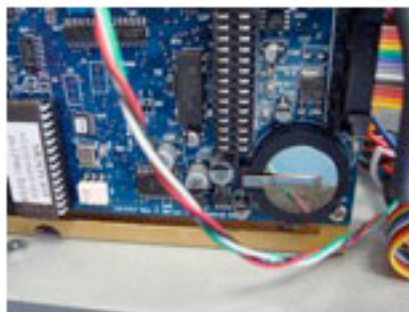

PCA with Battery



PCA without Battery

5 Quick Guide to Problem Solving

You Notice	This May Mean	Possible Cause	You Should
<ol style="list-style-type: none"> 1. Uneven pressure trace. 2. Pressure drops. 3. Pump shuts OFF. 4. No flow out the outlet check valve. 	<ol style="list-style-type: none"> 1. Bubble in check valve. 2. Leaks in system. 3. Dirty check valve. 4. Bad check valve. 	<ol style="list-style-type: none"> 1. Solvent not properly degassed. 2. Fittings are not tight. 3. Mobile phase not properly filtered. 4. Particles from worn piston seal caught in check valve. 5. Plugged inlet filter. 	<ol style="list-style-type: none"> 1. Check to be certain that mobile phase is properly degassed. 2. Check connections for leaks by tightening fittings. 3. Prime the system directly from the outlet check valve. 4. Clean or replace the check valves. See Section 4.4. 5. Replace inlet filter. See Section 4.1.1.
<ol style="list-style-type: none"> 1. Uneven pressure trace. 2. Pressure drops. 3. Fluid between the pump head and the chassis. 	<ol style="list-style-type: none"> 1. Leaks in system. 2. The piston seal(s) are worn. 	<ol style="list-style-type: none"> 1. Fittings not tight. 2. Long usage time since last seal change. 3. Salt deposits on seal (especially if buffered aqueous mobile phases are used without the self-flush head.) 	<ol style="list-style-type: none"> 1. Check all connections for leaks. 2. Replace piston seal. See Sections 4.2.3 and 4.3. 3. Check the piston for salt deposits. Clean as necessary. See Section 4.2.3.2
Pump makes a loud clanging or slapping noise (intermittent contact with cam).	Piston carrier is catching in piston guide.	<ol style="list-style-type: none"> 1. Cap nut screws on the pump head are loose. 2. Seal(s) are worn. 3. Piston guide is worn 4. Salt build-up on piston carrier from use of buffers. 5. Excess lubricant on piston carrier. 	<ol style="list-style-type: none"> 1. Check cap nut screws on pump head. Tighten if necessary. 2. Replace seals. 3. Replace seal backup washer and seal. See Sections 4.2 and 4.3. 4. Consider changing to a self-flushing pump head if using buffers. 5. Clean excess lubricant and dirt off piston carrier. See Section 4.8.
Blue dye in mobile phase.	Pulse damper diaphragm has burst.	Sudden pressure drop when purging system.	Replace pulse damper. See Section 4.5.
Pump runs for 50 pump strokes, and then shuts down.	Lower pressure limit is activating.	<ol style="list-style-type: none"> 1. Mobile phase is not properly filtered. 2. Particles from worn seal trapped in the system (e.g., tubing, filters, injection valve, column inlet). 	<ol style="list-style-type: none"> 1. Check to be certain the low-pressure limit is set to 0 psi. 2. Only increase the low-pressure limit after the pump attains operating pressure. 3. Contact service technician.
<ol style="list-style-type: none"> 1. Pump shuts down after run is called even with no column connected. 2. Pump runs to maximum pressure and shuts down. 	Clog in fluid system.		<ol style="list-style-type: none"> 1. Remove and clean both the inlet and bulkhead filters. See Sections 4.1.1 and 4.1.2. 2. If the problem persists, remove tubing from system one piece at a time until you find the clogged piece. Most clogs occur outside the pump itself.
No power when pump turned ON. Fan does not run.	Blown fuses in the power entry module.	<ol style="list-style-type: none"> 1. Power surge. 2. Internal short. 	<ol style="list-style-type: none"> 1. Replace only with the appropriate fuses 1A 250Vac. 2. Contact service technician if problem persists.
Front panel appears OK but pump motor does not run.	Blown fuse on the motor power circuit board.	<ol style="list-style-type: none"> 1. Power surge. 2. Internal short. 	<ol style="list-style-type: none"> 1. Replace only with the appropriate fuse. 2. Contact service technician if problem persists.
Self-flush heads leak flush solution.	Flush area not sealed.	<ol style="list-style-type: none"> 1. Large (Size O16) O-ring is flattened and no longer seals. 2. Head not sufficiently tightened. 3. Scratches in mating surfaces. 4. Leaky self-flush seal. 	<ol style="list-style-type: none"> 1. Replace O-ring. 2. Tighten head. 3. Replace leaky parts.

6 List of Replacement Parts

6.1 Supercritical Pump, Stainless Steel

880405.....	Supercritical check valve kit
210140	1/16" gland nut (pkg of 10 for outlet tubing)
210142	1/16" ferrule (pkg of 10 for outlet tubing)
210141	1/8" gland nut (pkg of 10 for outlet tubing)
210143	1/8" ferrule (pkg of 10 for outlet tubing)
880617	Transducer/Tee Assembly
250114	High-Pressure Outlet Filter Assembly, bulkhead, 2 micron
880702	Replacement 2 micron filter elements (pkg of 2)
050200	1/8" Inlet filter, bulkhead, 2 micron

6.2 Seals

880210.....	Supercritical Seal Kit
-------------	------------------------

6.3 General

880354.....	Piston assembly, 12mL
880992.....	Timing belt
931631.....	6.25 A slow-blo fuse (120V)
931634	3.15 A slow-blo fuse (240V)
931632	10 A fast-blo fuse (motor drive)
931790	Battery CR2025 or equivalent
902353	CO2 Tank Adapter

7 APPENDIX A

7.1 Rear Panel Remote Input

An RS-232C modular jack is provided on the back panel. A computer, with appropriate software, can be used as a remote controlling device for pump operation via this connection.

7.1.1 Hardware Implementation

The RS-232 I/O serial communications port is configured for 9600 baud, 8 data bits, 1 stop bit, and no parity. The connector is a standard RJ-11 modular telephone type jack. The pinout is:

<u>Pin</u>	<u>Function</u>
1, 6	Ground
2	DSR (Handshaking Input to pump)
3	RXD (Serial data input to pump)
4	TXD (Serial data output from pump)
5	DTR (Handshaking output from pump)

Special wiring considerations: Use the following chart for interfacing the Supercritical 24 pump serial communications port to either a 25-pin or 9-pin serial COM port on the computer.

<u>Pump (RJ11)</u>	<u>Signal</u>	<u>IBM (DB25)^a</u>	<u>IBM (DB9)^b</u>
1, 6	Ground	7	5
2	DSR	20	4
3	RXD	2	3
4	TXD	3	2
5	DTR	6	6

^a Jumper pins 4, 5, and 8 on DB25.
^b Jumper pins 1, 7, and 8 on DB9.

<u>Cable</u>	<u>Part Number</u>
Modular Cable	12-0677
Adapter RJ-11 to DB9	12-0672
Adapter RJ-11 to DB-25	12-0671

7.1.2 Hand-Shaking

The Supercritical pump uses hardware handshaking. The pump will not transmit on the TXD output if the DSR input is at a low logic level. And, the pump will not receive on the RXD input when the DTR output is at a low logic level. A low logic level is -3.0 to -15 volts and a high logic level is 3.0 to 15 volts.

7.1.3 Command Interpreter

The Supercritical 24 pump's high level command interpreter receives and responds to command packets. The pump will not send a message except when prompted, and it will send a response to valid command as described below. The response to an invalid command is "Er/".

Each command is characterized by a unique two-letter command code, and only one command can be issued per line. Case is not important; that is, the command codes "CC" "Cc" "cC" and "cc" are all equivalent. Command strings sent by the pump are terminated by the "/" character.

If the pump's response is "Er/", send a "#" to clear any characters which may be remaining in the command buffer. The pump will automatically clear all characters in the command buffer after one second elapses from the time at which the last character of an incomplete command was sent.

The command packets are as follows:

Command	Response	Comments
RU	OK/	Sets the pump to the RUN state.
ST	OK/	Sets the pump to the STOP state.
FOxxxx	OK/	Sets the flow rate to xx.xx or xxx.x mL/min where the range is fixed for the pump head size, i.e., for 0.01 to 10.00 mL/min xxxx = 0001 to 1000, for 0.1 to 40.0 mL/min xxxx = 0001 to 0400.
PR	OK,x/ (x, xx, xxx, or xxxx)	Reads the pump's current pressure, where: x, xx, xxx, or xxxx = Current pressure in PSI
CC	OK,x,y.yy/ (x, xx, xxx, or xxxx) (y.yyy, y.yy, yy.yy, or yy.y)	Reads the pump's current pressure and flowrate, where: x, xx, xxx, or xxxx = Current pressure in PSI y.yyy, y.yy, yy.yy, or yy.y = Flow rate in mL/min The format is y.yy and yy.yy for a standard pump head, y.yyy for micro pump head or yy.y for a macro pump head.
CS	OK,x.xx,y,z,PSI,w,v,u/ (x.xxx, xx.xx, or xxx.x) (y, yy, yyy, or yyyy) (z, zz, zzz, or zzzz)	Reads the current pump setup, where: x.xxx, xx.xx, or xxx.x = Flow rate in mL/min y, yy, yyy, or yyyy = Upper pressure limit z, zz, zzz, or zzzz = Lower pressure limit PSI = Units (PSI, ATM, MPA, BAR, or KGC) w = Pump head size (0 = standard, 1 = macro) v = Run status (0 = stopped, 1 = running) u = Pressure Board present = 0; otherwise 1
ID	OK,vx.xx SR30 firmware/	Identifies the pump type and EPROM revision x.xx
UPxxxx	OK/	Sets the upper pressure limit in PSI. The maximum value for xxxx is 5000 for the plastic head or 6000 for the steel head; the minimum value is the lower limit plus 100. The value must be expressed as four digits, i.e., for 900 PSI xxxx = 0900.

LPxxxx	OK/	Sets the lower pressure limit in PSI. The maximum value for xxxx is the current upper pressure limit setting minus 100; the minimum value is 0. The value must be expressed as four digits, i.e., for 100 PSI xxxx = 0100.
SF	OK/	Puts the pump in fault mode. Turns on the FAULT LED and stops the pump immediately.
RF	OK,x,y,z/	Reads the fault status, where: x = Motor stall fault (0 = no, 1 = yes) y = Upper pressure limit fault (0 = no, 1 = yes) z = Lower pressure limit fault (0 = no, 1 = yes)
KD	OK/	Disables the keypad. (Default status at power-up is enabled.)
KE	OK/	Enables the keypad.
PCxx	OK/	Sets the pressure compensation value, where xx = the operating pressure (in PSI divided by 100), i.e., for 0 PSI xx = 00, for 5000 PSI xx = 50.
RC	OK,x/ (x or xx)	Reads the pressure compensation value in hundreds of PSI, i.e., for 0 PSI x = 0, for 5000 PSI xx = 50.
HTx	OK/	Sets the pump head type, where: x = 1 for a stainless steel 12 mL/min pump head The pump is stopped; and, the pressure compensation and pressure limits are initialized, when the head type is changed.
RH	OK,x/	Reads the pump head type, where: x = 1 for a stainless steel 12 mL/min pump head x = 2 for a plastic 12 mL/min pump head x = 3 for a stainless steel 50 mL/min pump head x = 4 for a plastic 50 mL/min pump head x = 5 for a stainless steel 6mL/min pump head x = 6 for a plastic 6 mL/min pump head
PI	OK, a.aa, b, c, d, e, f, g, h, i, j, k, l, m, n, o, p, q/ (a.aaa, a.aa, aa.aa, or aa.a) (c or cc)	Reads the current pump setup, where: a.aaa, a.aa, aa.aa, or aa.a = Flow rate in mL/min b = Run status (0 = stopped, 1 = running) c or cc = Pressure compensation d = Pump head type (see RH command) e = Pressure Board present = 0; otherwise 1 f = External control mode (0 = frequency, 1 = voltage) g = 1 if pump started and frequency controlled, else 0 h = 1 if pump started and voltage controlled, else 0 i = Upper pressure limit fault (0 = no, 1 = yes) j = Lower pressure limit fault (0 = no, 1 = yes) k = Priming (0 = no, 1 = yes) l = Keypad lockout (0 = no, 1 = yes) m = PUMP-RUN input (0 = inactive, 1 = active) n = PUMP-STOP input (0 = inactive, 1 = active) o = ENABLE IN input(0 = inactive, 1 =active) p = Always 0 q = Motor stall fault (0 = no, 1 = yes)
RE	OK/	Resets the pump configuration to its default power-up state.
SPxxxx	OK/	Sets the Pressure to xxxx PSI.
#	(no response)	Clears all characters from the command buffer.

7.2 Rear Panel 6-Pin and 10-Pin Terminal Board Connectors

A 6-pin terminal board connector and a 10-pin terminal board connector are provided on the back panel. Any device capable of providing the proper run/stop logic level, flowrate control frequency, or flowrate control voltage can be used as a remote controlling device for pump operation via this connection. The terminal board connectors can be removed for ease of connecting wires, if desired, by pulling firmly rearward and should be reinserted firmly afterward.

7.2.1 Pressure Fault and Motor Stall Fault Output

The pump's output is on the 6-pin terminal board connector.
The pinout is:

<u>Pin</u>	<u>Function</u>
6.....	EVENT 1
5.....	No Connection
4.....	EVENT 2
3.....	No Connection
2.....	EVENT 3
1.....	No Connection

This output is produced internally by a reed relay which has SPDT contacts with a 0.25 amp maximum, 50 VDC maximum, 0.2 ohm rating. The 6-pin connector allows wires to be connected to the EVENT 1 (Pole), EVENT 2 (NC), and EVENT 3 (NO) terminals. When the pump stops due to the sensed pressure exceeding the set pressure limits or if a motor stall fault occurs, the connection between the EVENT 1 terminal and the EVENT 2 and EVENT 3 terminals is affected. EVENT 2 is Normally Closed (connected to EVENT 1) until a fault occurs and then opens. EVENT 3 is Normally Open (not connected to EVENT 1) until a fault occurs and then closes.

7.2.2 General Information on Inputs

The pump's inputs are on the 10-pin terminal board connector.
The pinout is:

<u>Pin</u>	<u>Function</u>
10.....	VOLTAGE COM
9.....	VOLTAGE IN
8.....	FREQ IN
7.....	ENABLE IN
6.....	PUMP-RUN
5.....	PUMP-STOP
4.....	No connection
3.....	No connection
2.....	No connection
1.....	COM

7.2.3 General Information on Run, Stop, and Enable Inputs

The PUMP-RUN, PUMP-STOP, and ENABLE IN inputs operate from an internal 5 VDC source and each one draws approximately 0.008 amps when connected to COM. To activate either the PUMP-RUN, PUMP-STOP, or ENABLE IN input connect it to COM. Any device capable of switching 0.008 amps can be connected between the PUMP-RUN, PUMP-STOP, or ENABLE IN input and COM, such as: a switch contact, a relay contact, an open collector output, an open drain output, or any output with a high logic level output of 3.8 to 6.0 volts and a low logic level output of 0.0 to 0.5 volts. A switch contact or a relay contact is preferred since this type of connection will provide isolation between the pump and the controlling device. The COM terminal is internally connected to the pump's chassis ground and should be connected to the controlling device's ground or zero volt terminal when the controlling device has an open collector output, an open drain output, or any output with logic level output.

7.2.4 Run and Stop Inputs

The pump's motor can be commanded to run or stop from the back panel inputs when the pump's flow rate is controlled from the front panel or when the pump's flow rate is controlled by the voltage or frequency input. There two modes of operation for the run and stop inputs which are described below:

Dual Signal Pulse: In this mode of operation both the PUMP-RUN and PUMP-STOP inputs are normally at a high logic level. To start the pump, pulse the PUMP-RUN input to a low logic level for a minimum of 500 mS. To stop the pump, pulse the PUMP-STOP input to a low logic level for a minimum of 500 mS.

Single Signal Level: To enable this mode of operation the PUMP-STOP input must be permanently connected to COM with a jumper wire. To start the pump, put a low logic level on the PUMP-RUN input. To stop the pump, put a high logic level on the PUMP-RUN input.

7.2.5 Enable Input

When activated (ENABLE IN is at a low logic level), the ENABLE IN input disables flow rate control on the front panel and enables flow rate control on the back panel.

7.2.6 General Information on Voltage and Frequency Inputs

Special programming and circuitry allows this pump to be operated remotely with the flow rate controlled by voltage or frequency inputs. To select the remote mode of operation:

1. With the pump plugged in and the rear panel power switch OFF, press in and hold the "DOWN ARROW" button while turning the power switch ON.
2. Release the "DOWN ARROW" button and either a U (closest approximation to V for voltage) or an F (for frequency) will be displayed.
3. Select the desired remote operating mode by pressing the "DOWN ARROW" button to toggle between the voltage and frequency mode.

4. Press the "RUN/STOP" button to place the pump in normal operating mode.
5. To enable the currently selected remote mode (voltage or frequency), connect the rear panel ENABLE IN connection to the COM connection.
6. When in the remote mode (ENABLE IN at a low logic level) all front panel buttons remain active except the flow setting increase/decrease capability.

7.2.7 Voltage Input

The remote voltage flow control is implemented by connecting a negative input to the rear panel VOLTAGE COM connection and a positive input to the VOLTAGE IN connection. A 0-10 VDC input corresponds to a 0 to 10 mL/min for 10mL pumps and 0 to 40 mL/min for 40 mL pumps. Any device capable of sourcing at least 0.0005 amps will work. Also, the voltage control mode must be selected and enabled as described in section "7.2.5" above. The voltage source, which drives the VOLTAGE IN and VOLTAGE COM connections, must be isolated from the safety ground to prevent a ground loop current. If the pump's displayed flow rate jumps up and down erratically, suspect a ground loop problem. Flow rate instabilities may exist for input voltages below 10mV.

7.2.8 Frequency Input

The remote frequency flow control is implemented by connecting a negative input to the COM connection and +5 VDC square wave input to the FREQ IN connection. Any device capable of sinking and sourcing at least 0.008 amps will work. A 0 to 10,000 Hertz input frequency will correspond to a 0 to 10 mL/min flow rate for 10mL pumps and 0 to 40 mL/min for 40mL pumps. Also, the frequency control mode must be selected and enabled as described in section "7.2.5" above.

8 Warranty Statement

Teledyne SSI (SSI) warrants that instruments or equipment manufactured by the company for a period thirty-six (36) months from date of shipment to the original purchaser (or to the drop ship location as indicated on the Purchase Order from the original purchaser), against defects in materials and workmanship under normal installation, use and maintenance. Products sold by SSI but not manufactured by SSI carry the Original Manufacturer's Warranty, beginning as of the date of shipment to SSI's original purchaser. Expendable items and physical damage caused by improper handling or damage caused by spillage or exposure to any corrosive environment are excluded from this warranty. The warranty shall be void for Polyetheretherketone (PEEK) components exposed to concentrated Nitric or Sulfuric acids which attack PEEK, or methylene chloride, DMSO or THF which adversely affect UHMWPE seals and PEEK tubing. Any defects covered by this warranty shall be corrected by replacing or repairing, at SSI's option, parts determined by SSI to be defective.

Spare or replacement parts and accessories shall be warranted for a period of twelve (12) months from date of shipment to the original purchaser against defects in materials and workmanship under normal installation, use and maintenance. Defective Product will be accepted for return to SSI only if the request for return is made within thirty (30) days from the time of discovery of the alleged defect, and prior to return, the original purchaser obtains a Return Goods Authorization (RGA) number from SSI, and provides SSI with the serial number of each instrument to be returned.

The warranty shall not apply to any Product that has been repaired or altered except by SSI or those specifically authorized by SSI, to the extent that such repair or alteration caused the failure, or to Product that has been subjected to misuse, negligence, accident, excessive wear, or other causes not arising out of a defect in material or workmanship.

The warranty shall not apply to wear items, specifically:

- Check Valves
- Piston and Wash Seals
- Pistons
- Pulse-Damper Diaphragms
- Inlet Lines
- Filter Elements

The following is the exclusive procedure by which to make claims under this warranty. Customer shall obtain SSI's oral or written authorization to return the Product and receive a Return Goods Authorization (RGA) number. The Product must be returned with the RGA number plainly visible on the outside of the shipping container to SSI. It must be securely packed in a rigid container with ample cushioning material, preferably the original packaging. All claimed defects must be specified in writing, including the RGA number, with the written claim accompanying the Product. Freight costs for the return of reported defective Product from the original purchaser to SSI is the responsibility of the original purchaser. Freight costs for the return of reported defective spare parts is the responsibility of SSI. SSI shall specify the freight carrier for returns. SSI shall bear the expense of return shipment to original purchaser (or to the drop ship location as indicated on the Purchase Order from the original purchaser).

If it appears to SSI that any Product has been subjected to misuse, negligence, accident or excessive wear, or is beyond the warranty period, the original purchaser and/or customer shall be notified promptly. SSI shall communicate its finding and provide an estimate to repair such Product at the then current rates for parts and service. SSI shall either repair the Product per customer's authorization or shall return such Product not repaired to customer at customer's expense. SSI may invoice customer for the freight costs of any Product shipped back to the original purchaser and/or customer by SSI which is not covered under the warranty.

Limitations of Warranty. THE FOREGOING WARRANTIES AND LIMITATIONS ARE CUSTOMER'S EXCLUSIVE REMEDIES AND ARE IN LIEU OF ALL OTHER WARRANTIES, EXPRESS OR IMPLIED, INCLUDING WITHOUT LIMITATION ANY WARRANTY OF MERCHANTABILITY OR FITNESS FOR A PARTICULAR PURPOSE.